



Chariot

- 1 - Tablettes coulissantes
- 2 - 2 roues tout terrain
- 3 - 2 roues pivotantes avec frein
- 4 - 1 porte - poignée aluminium

structure
garantie
2 ans



CHARIOT ENOSIGN 65 noir & inox

REF: 570282858801
EAN: 3224780041221

DESCRIPTION PRODUIT

- Structure acier galvanisé et inox qualité marine
- 2 tablettes
- 2 roues tout terrain – 2 roues directionnelles à frein
- 1 porte noire – poignée aluminium porte ustensiles
- Coloris noir & inox

LIVRÉ PRÉ-MONTÉ

COMPATIBLE AVEC

- Housse pop-up HCI065
- Plancha Enosign 65 Noir & inox 570232014801
- Capot CPS6585

LES + PRODUIT

25%
ÉCONOMIE
ÉNERGIE

Éco-conception

DESIGN
SIGNATURE

BY
ENO

MATÉRIAUX
RÉSISTANTS

Inox de qualité
et acier galvanisé

ENTRETIEN
FACILE

Finitions
soignées



CHARIOT ENOSIGN 65 noir & inox

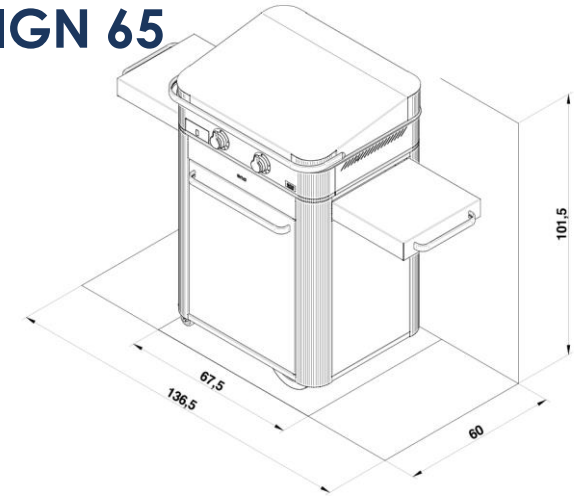

Code article	570282858801
Gencode	3224780041221
Nom article	CHARIOT ENOSIGN 65 Noir et inox
Nb Personnes	
Surface cuisson	
Homologation	CE, ALIMENTAIRE, Longtime
Utilisation	Exterieur
Dim. Produit (H x L x P)	80 x 126 x 57 cm / 31,5" x 49,61" x 22,44"
Dim. emballage (H x L x P)	80 x 70 x 55 cm / 31,5" x 27,56" x 21,65"
Poids net	34 kg / 74,97 lbs
Poids Emballé	38,5 kg / 84,89 lbs
PCB	1
Nb colis/article	1
Nb pcs/pal	4
Energie	
Type branchement	
Nb brûleurs	
Puissance brûleurs kW	
Consommation	349 g/h
Allumage sécurité	thermocouple
Plaque	
Revêtement plaque	
Détails plaque	
Châssis	
Protection	
Coloris	
Détails	
Garanties: plaque, brûleurs, autres pieces	
Origine	Origine France Garantie
Ecotaxe DEEE HT	
Taxe Ecomobilier HT	0,11
Taux TVA	20%
Code douanier	73211190
Notice	85559.pdf





Trolley
1 - Sliding shelves
2 - 2 all-terrain wheels
3 - 2 swivel wheels with brakes
4 - 1 door - aluminium handle

structure
2 years
warranty



Trolley ENOSIGN 65 black & stainless

REF: 570282858801
EAN: 3224780041221

PRODUCT DESCRIPTION

- Galvanised steel and marine-grade stainless steel structure
- 2 shelves
- 2 all-terrain wheels- 2 directional wheels with brake
- 1 black door – aluminium utensil holder handle
- Protective lid with brake
- Black & stainless color

DELIVERED PRE-ASSEMBLED

COMPATIBLE WITH

- Cover trolley HCI065
- Plancha Enosign 65 Black & stainless 570232014801
- Lid CPS6585

+ PRODUCT

25% ENERGY
SAVINGS

Eco-design

SIGNATURE
DESIGN

BY
ENO

RESISTANT
MATERIALS

Quality stainless steel
and galvanised steel

ESAY
TO CLEAN

Meticulous
finishes

Trolley ENOSIGN 65 black & stainless

# article	570282858801
Gencod	3224780041221
Article name	TROLLEY ENOSIGN 65 Black and stainless
Description	Trolley for plancha ENOSIGN 65
Capacity	
Cooking Area	
Certification	CE, FOOD CONTACT, Longtime_en
Usage	Outdoor
Product dim.(H x L x P)	80 x 126 x 57 cm / 31,5" x 49,61" x 22,44"
Packaging dim. (H x L x P)	80 x 70 x 55 cm / 31,5" x 27,56" x 21,65"
Net weight	34 kg / 74,97 lbs
Gross weight	38,5 kg / 84,89 lbs
Per outer	1
Nb box/SKU	1
Nb SKU/pal	4
Energy	
Connexion	
Nb burners	
Output	
Consumption	349 g/h
Ignition	
Safety	thermocouple
Plate	
Plate coating	
Plate details	
Frame	
Coating	
Colour	
Details	
Waranty	
Manufacturing origin	Origine France Garantie
User manual	85559.pdf
Customs code	73211190

